

Kawasaki

— ENGINES —

OWNER'S MANUAL
MANUEL DU PROPRIETAIRE
BENUTZERHANDBUCH
MANUALE D'ISTRUZIONI
MANUAL DEL PROPIETARIO
GEBRUIKERSHANDLEIDING
MANUAL DO PROPRIETÁRIO

FR541V
FR600V

ENGLISH

General-purpose Engine Owner's Manual

SAFETY AWARENESS

Whenever you see the symbols shown below, heed their instructions! Always follow safe operating and maintenance practices.

DANGER

DANGER indicates a hazardous situation which, if not avoided, will result in death or serious injury.

WARNING

WARNING indicates a hazardous situation which, if not avoided, could result in death or serious injury.

CAUTION

CAUTION indicates a hazardous situation which, if not avoided, could result in minor or moderate injury.

NOTICE

NOTICE is used to address practices not related to personal injury.

NOTE

- *This note symbol indicates points of particular interest for more efficient and convenient operation.*

READ THE OPERATING INSTRUCTIONS OF THE EQUIPMENT THIS ENGINE POWERS.

READ THIS FIRST

For your safety, read this Owner's Manual and understand it thoroughly before operating this ENGINE.

DANGER

Exhaust gas contains carbon monoxide, a colorless, odorless poisonous gas. Inhaling carbon monoxide can cause serious brain injury or death. **DO NOT** run the engine in enclosed areas. Operate only in a well-ventilated area. Gasoline is extremely flammable and can be explosive under certain conditions, creating the potential for serious burns. When refueling, servicing fuel system, draining gasoline and/or adjusting the carburetor: **Stop engine and allow it to cool before refueling. DO NOT smoke.** Make sure the area is well-ventilated and free from any source of flame or sparks, including the pilot light of any appliance.

DO NOT fill the tank so the fuel level rises into the filler neck or level surface of level gauge. If the tank is overfilled, heat may cause the fuel to expand and overflow through the vents in the tank cap. **Wipe off any spilled gasoline immediately.**

Engines can become extremely hot during normal operation. To prevent fire hazard: **Keep the engine at least 1 m (3.3 ft) away from buildings, obstructions and other burnable objects. DO NOT place flammable objects close to the engine. DO NOT expose combustible materials to the engine exhaust. DO NOT use the engine on any forest covered, brush covered or grass covered unimproved land unless spark arrester is installed on the muffler.**

To avoid getting an electric shock, **DO NOT touch spark plugs, plug caps or spark plug leads during engine running.**

To avoid a serious burn, **DO NOT touch a hot engine or muffler.** The engine becomes hot during operation. Before you service or remove parts, stop engine and allow the engine to cool.

DO NOT place hands or feet near moving or rotating parts. Place a protective cover over pulley, V belt or coupling.

DO NOT run engine at excessive speeds. This may result in injury.

Always remove the spark plug caps from spark plugs when servicing the engine to prevent accidental starting.

Read warning labels which are on the engine and understand them. If any label is missing, damaged, or worn get a replacement from your Kawasaki engine dealer and install it in the correct position.

FOREWORD

This Owner's Manual provided to aid you in the safe and reliable operation of your Engine. **READ AND UNDERSTAND IT THOROUGHLY BEFORE OPERATING YOUR ENGINE.**

READ THE OPERATING INSTRUCTIONS OF THE EQUIPMENT THIS ENGINE POWERS.

To ensure a long, trouble-free life for your Engine, give it proper care and maintenance in accordance with this Owner's Manual.

Please note that the photographs and illustrations shown in this manual are made based on Model FR600V as a typical example among other similar models.

All rights reserved. No part of this publication may be reproduced, stored in a retrieval system, or transmitted in any form or by any means, electronic mechanical photocopying, recording or otherwise, without the prior written permission of Kawasaki Motors, Ltd.. Although every possible care has been taken to make this manual as complete and accurate as possible, Kawasaki cannot guarantee against errors and omissions. Due to improvements in design and performance during production, procedures and specifications are subject to change without prior notice. Illustrations are provided for general reference purposes, and may differ from actual product aspects and components.

TABLE OF CONTENTS

GENERAL INFORMATION	7	Throttle Cable Installation, Adjustment.....	20
Label Location	7	Choke Cable Installation, Adjustment	20
Parts Location	8	Engine Speed Adjustment.....	22
Tune-up Specifications	9	MAINTENANCE	23
Engine Oil Capacity.....	10	Periodic Maintenance Chart	23
FUEL AND OIL RECOMMENDATIONS	11	Oil Level Check	25
Fuel	11	Oil Change	26
Engine Oil.....	12	Oil Filter Change	27
PREPARATION	13	Air Cleaner Service	28
Fuel	13	Air Cleaner Element	28
Engine Oil.....	13	Spark Plug Service.....	29
STARTING	15	Fuel Filter and Fuel Pump Service	30
Starting the Engine.....	15	Cooling System Cleaning	31
OPERATING	17	STORAGE	33
Warming Up.....	17	Fuel System Draining	33
Engine Inclination.....	18	TROUBLESHOOTING GUIDE	35
STOPPING	19	ENVIRONMENTAL PROTECTION	37
Stopping the Engine	19	SPECIFICATIONS	38
Emergency Stop.....	19	WIRING DIAGRAM	39
ADJUSTMENT	20	Wiring Diagram.....	39

GENERAL INFORMATION

Label Location

The engine serial number is your only means of identifying your particular engine from others of the same model type.

This engine serial number is needed by your dealer when ordering parts.



1. Warning Label
2. Important Engine Information Label
3. Engine Serial Number Label

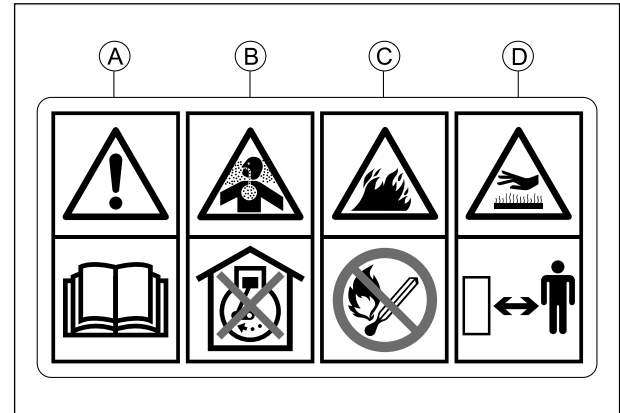

Warning Label

- A. The Owner's manual contains important information on safe operation. Read it before operating engine.
- B. Exhaust gas contains carbon monoxide, an odorless and deadly poison.
Do not run Engine in an enclosed area.
- C. Gasoline is extremely flammable and explosive.
No open flames or other source of ignition.
- D. Engines can become extremely hot during normal operation. Keep away from hot parts of the engine.

8 GENERAL INFORMATION

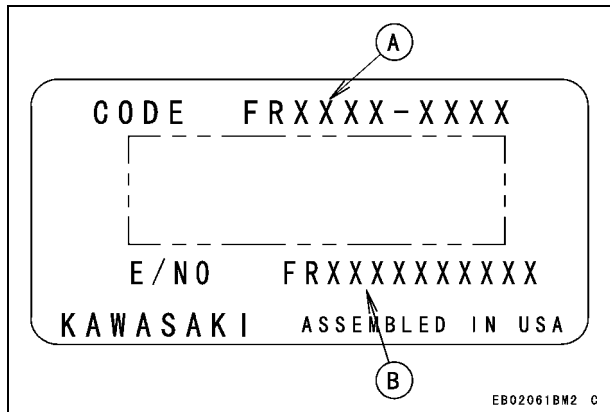

- A. Model Code
- B. Engine Serial Number

Parts Location

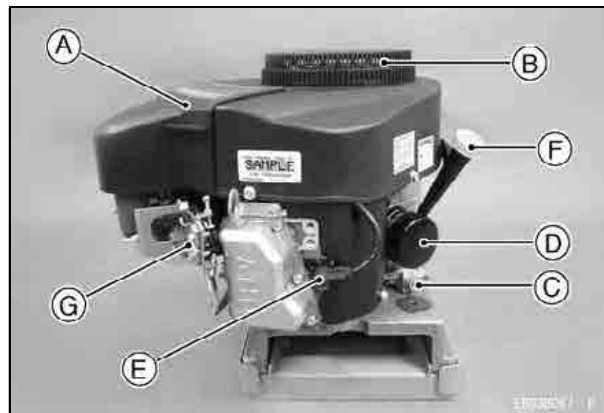

- A. Air Cleaner (inside A)
- B. Air Inlet Guard
- C. Oil Drain Plug
- D. Oil Filter
- E. Spark Plugs/Spark Plug Caps
- F. Oil Gauge/Filler Cap
- G. Control Panel

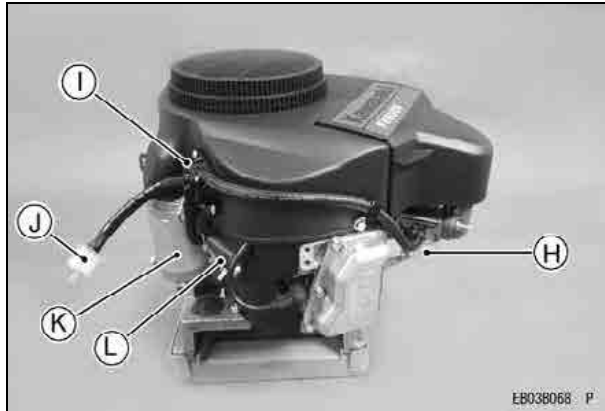

- H. Carburetor
- I. Fuel Pump
- J. Fuel Filter
- K. Electric Starter
- L. Voltage Regulator

Tune-up Specifications

ITEM	Specifications
Ignition Timing	Unadjustable
Spark Plugs: Gap	NGK BPR4ES 0.75 mm (0.030 in.)
Low Idle Speed	1 550 r/min (rpm)
High Idle Speed	3 600 r/min (rpm)
Valve Clearance	In 0.10 ~ 0.15 mm (0.004 ~ 0.006 in.) Ex 0.10 ~ 0.15 mm (0.004 ~ 0.006 in.)
Other Specifications	No other adjustment needed

NOTE

○ High and low idle speeds may vary depending on the equipment on which the engine is used. Refer to the equipment specification.

10 GENERAL INFORMATION

Engine Oil Capacity

Engine Oil Capacity

FR541V	1.5 L [when oil filter is not removed]
FR600V	1.7 L [when oil filter is removed]

FUEL AND OIL RECOMMENDATIONS

Fuel

Use only clean, fresh, unleaded regular grade gasoline.

NOTICE

Do not mix oil with gasoline.

Octane Rating

The octane rating of a gasoline is a measure of its resistance to “knocking”. Using a minimum of 91 octane by the RON is recommended.

RON = Research Octane Number

NOTE

○ If “knocking or pinging” occurs, use a different brand of gasoline or higher octane rating.

Oxygenated Fuel

Oxygenates (either ethanol or MTBE) are added to the gasoline. If you use the oxygenated fuel be sure it is unleaded and meets the minimum octane rating requirement.

The following are the EPA approved percentages of fuel oxygenates.

ETHANOL: (Ethyl or Grain Alcohol)

You may use gasoline containing up to 10% ethanol by volume.

MTBE: (Methyl Tertiary Butyl Ether)

You may use gasoline containing up to 15% MTBE by volume.

METHANOL: (Methyl or Wood Alcohol) 5% by volume

You may use gasoline containing up to 5% methanol by volume, as long as it also contains cosolvents and corrosion inhibitors to protect the fuel system. Gasoline containing more than 5% methanol by volume may cause starting and/or performance problems. It may also damage metal, rubber, and plastic parts of your fuel system.

12 FUEL AND OIL RECOMMENDATIONS

Engine Oil

The following engine oils are recommended.
API Service Classification : SJ or higher class.

Oil Viscosity

Choose the viscosity according to the temperature as follows:

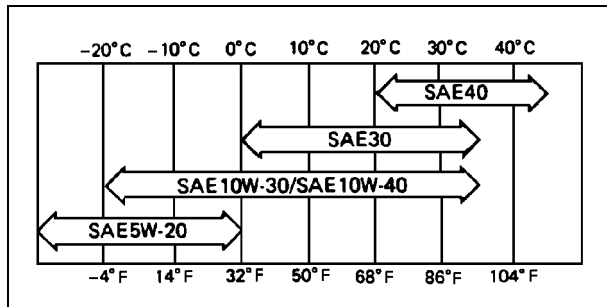

NOTE

- Using multi grade oils (5W-20, 10W-30, and 10W-40) will increase oil consumption. Check oil level more frequently when using them.

PREPARATION

Fuel

WARNING

Gasoline is extremely flammable and can be explosive under certain conditions, creating the potential for serious burns. When refueling, servicing fuel system, draining gasoline and/or adjusting the carburetor: Stop engine and allow it to cool before refueling. DO NOT smoke. Make sure the area is well-ventilated and free from any source of flame or sparks, including the pilot light of any appliance. DO NOT fill the tank so the fuel level rises into the filler neck or level surface of level gauge. If the tank is overfilled, heat may cause the fuel to expand and overflow through the vents in the tank cap. Wipe off any spilled gasoline immediately.

Engine Oil

Check the engine oil daily before starting the engine otherwise shortage of the engine oil may cause serious damage to the engine such as seizure.

- Place the engine on level surface. Clean area around the oil gauge before removing it.
- Remove the oil gauge and wipe it with a clean cloth.
- Pour the oil slowly to “FULL” mark on the oil gauge.
- Insert the oil gauge into tube WITHOUT SCREWING IT IN.
- Remove the oil gauge to check the oil level. The level should be between “ADD” and “FULL” marks. Do not overfill.
- Install and tighten the oil gauge.

NOTICE

Do not fill above the “FULL” mark. Excess oil will cause a smoking condition, and may cause the engine to overheat.

Engine Oil Capacity

FR541V FR600V	1.5 L [when oil filter is not removed]
	1.7 L [when oil filter is removed]

14 PREPARATION

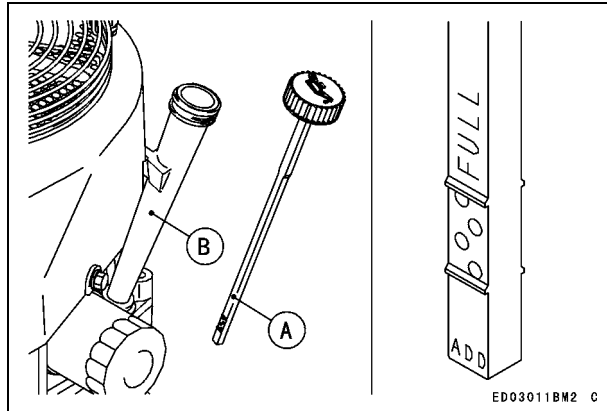

- A. Oil Gauge
- B. Tube

NOTICE

The engine is shipped without engine oil.

STARTING

Starting the Engine

⚠ WARNING

Exhaust gas contains carbon monoxide, a colorless, odorless poisonous gas. Inhaling carbon monoxide can cause serious brain injury or death. **DO NOT** run the engine in enclosed areas. Operate only in a well-ventilated area.

⚠ WARNING

Engine exhaust may ignite combustible materials and cause a fire. Keep the area around the exhaust outlet clear. Locate the unit so that the exhaust outlet points toward an open area and is located at least one meter (3.3 feet) from any obstructions.

NOTE

- Be aware of the following in order to start the engine easily in cold weather.
- Use proper oil for expected temperature (See “FUEL AND OIL RECOMMENDATIONS” chapter).
Use fresh gasoline.

Protect the engine or the equipment from direct exposure to weather when not in operation.

NOTE

- Follow the operating instructions of the equipment this engine powers.
- Before starting the engine, disconnect all possible external loads.
Open the fuel valve on the equipment. Move throttle lever on dash to half throttle position. Use full choke when the engine is cold, but in hot weather or when the engine is already warm, use half choke or leave the choke fully open.
- Put the switch key into the engine switch.
- Turn the switch key to the START position on the equipment. Usually engine will start within 3 seconds.

NOTICE

Do not run the electric starter continuously for more than 5 seconds, otherwise the battery may discharge quickly. If the engine does not start right away, wait 15 seconds and try again.

NOTE

- When the engine is very warm, or when the engine does not start immediately, **DO NOT** keep trying

16 STARTING

to start it with the choke closed as this will cause flooding and make starting more difficult.

○ *Instead, fully open the choke and start the engine.*

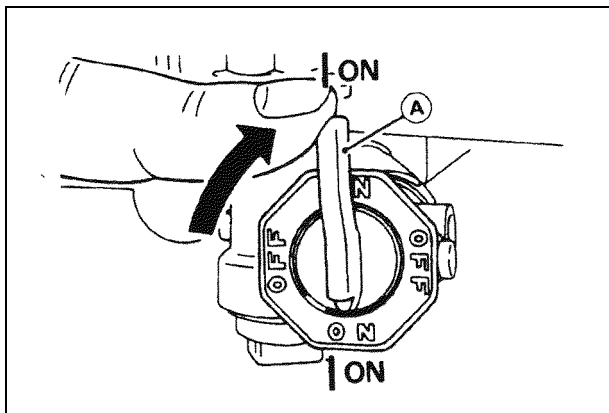

A. Fuel Valve

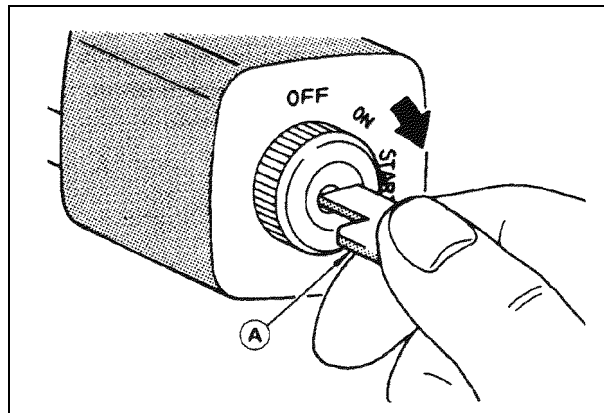

A. Switch Key

NOTICE

Whenever you start engine, make sure warning lamp is not illuminated after engine starts. If warning lamp comes on, stop engine immediately and check oil level (if equipped).

- After starting the engine, gradually return the choke lever to the fully open position.

OPERATING

Warming Up

After the engine starts, move the throttle lever on the equipment to halfway between “FAST” and “SLOW”.

To warm up the engine, run it for 3 to 5 minutes with the throttle lever in the same load position (halfway) before putting the equipment under load. Then, move the throttle lever (A) on the equipment to its “FAST” position.

NOTICE

Allow engine to warm up sufficiently (3 to 5 minutes at idle) before applying a load. This will allow oil to reach all engine parts, and allow piston clearance to reach design specifications.

NOTICE

While warming up the engine, make sure the warning lamp (oil pressure) on dash is not on. The warning lamp must not be illuminated during engine operation (if equipped).

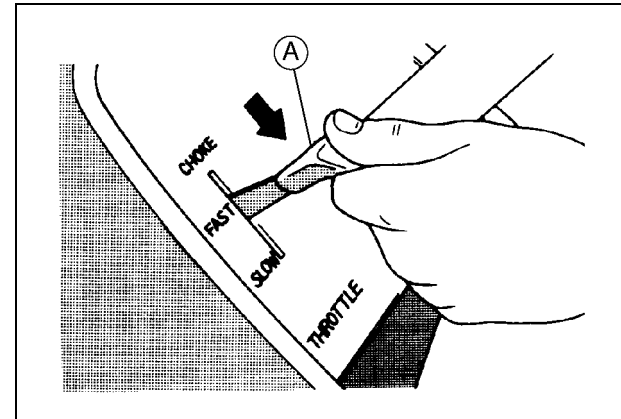

A. Throttle Lever

18 OPERATING

Engine Inclination

This engine will operate continuously at angles up to 25° in any direction.

Refer to the operating instructions of the equipment this engine powers. Because of equipment design or application, there may be more stringent restrictions regarding the angle of operation.

NOTICE

Do not operate this engine continuously at angles exceeding 25° in any direction. Engine damage could result from insufficient lubrication.

STOPPING

Stopping the Engine

⚠ WARNING

Leaving the equipment with the key hanging in the ignition can allow operation by someone who does not know how to operate it. It may cause serious accident with injury. Always remove the key from unattended equipment.

Ordinary Stop

- Move the throttle lever to “slow” position.
- Lower the engine speed to the idle speed. Keep running at the idle speed for about one minute.

NOTICE

Engine damage can occur from run-on or after-burning if engine is stopped suddenly from high speed loaded operation. Reduce engine speed to idle for one minute before shutting engine off.

- Turn the engine switch or the switch key to “OFF” position.

For Control Panel Switch Type, move the throttle lever against its low speed end to turn the ignition off.

Emergency Stop

- Immediately turn the engine switch or the switch key to “OFF” position.
Close the fuel valve on the equipment.
For Control Panel Switch Type, move the throttle lever on the equipment to its low speed end. Moving the lever to its low speed end turns ignition off.

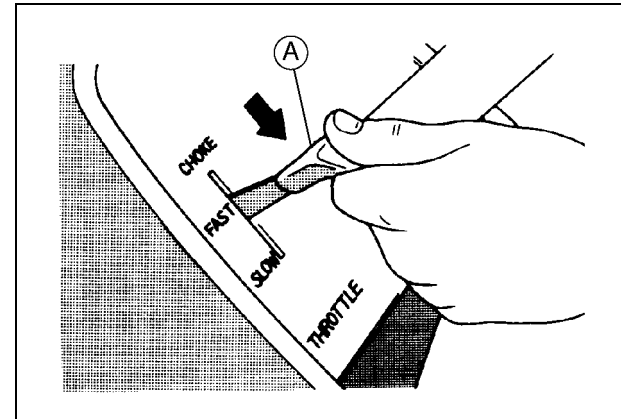

A. Throttle Lever

ADJUSTMENT

Throttle Cable Installation, Adjustment

- Link the throttle cable to the speed control lever and loosely clamp the throttle cable outer housing with the cable clamp bolt.
Move the throttle lever to “FAST” position.
Pull up the outer housing of the throttle cable until the inner wire has almost no slack, and tighten the cable clamp bolt.
Move the throttle lever to “SLOW” position. Make sure that the carburetor throttle valve is moved smoothly.

Choke Cable Installation, Adjustment

- Link the choke cable to the choke control lever, and loosely clamp the choke cable outer housing with the cable clamp bolt.
Move the equipment choke control to “OPEN” position. Make sure that the carburetor choke valve is fully opened.
Pull up the outer housing of the choke cable until the inner wire has almost no slack, and tighten the cable clamp bolt.
Move the equipment choke control to “CHOKE” position. Make sure that the carburetor choke valve is completely closed.
Make sure that the choke valve turns from fully closed position to fully opened position when actuating the equipment choke control.

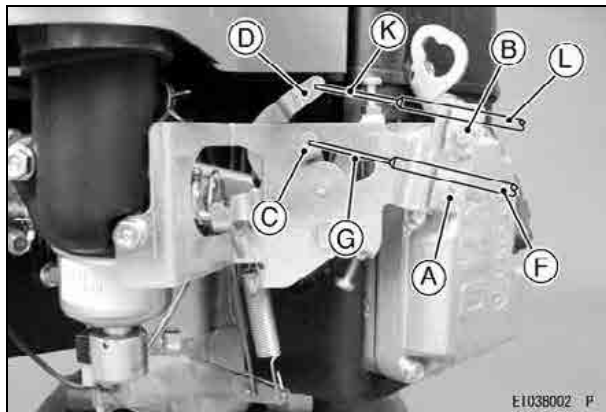

- A. B. Cable Clamp Bolt**
- C. Speed Control Lever**
- D. Choke Control Lever**
- F. Throttle Cable Outer Housing**
- G. K. Inner Wire**
- L. Choke Cable Outer Housing**

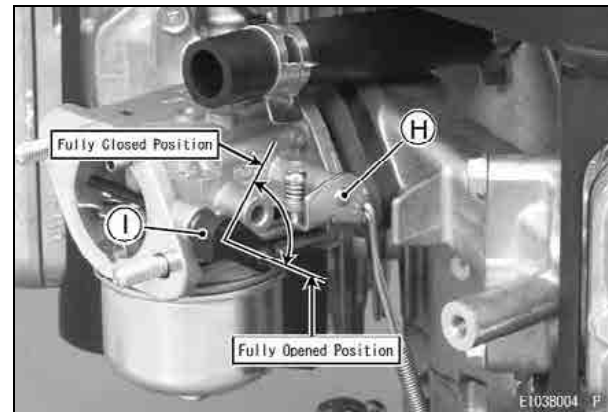

- H. Throttle Valve**
- I. Choke Valve**

22 ADJUSTMENT

Engine Speed Adjustment

NOTE

○ *Do not tamper with the governor setting or the carburetor setting to increase the engine speed. Every carburetor is adjusted at the factory and a cap or stop plate is installed on each mixture screw.*

○ *If any adjustment is necessary, it must be performed by your authorized Kawasaki Engine dealer.*

MAINTENANCE

Maintenance, replacement, or repair of the emission control devices and systems may be performed by any nonroad engine repair establishment or individual.

Periodic Maintenance Chart

⚠ WARNING

Prevent accidental starting during engine service by removing the spark plug caps.

NOTE

○ *The service intervals can be used as a guide. Service more frequently as necessary by operating conditions.*

◆ : Service more frequently under dusty conditions.

K : Service to be performed by an authorized Kawasaki dealer.

MAINTENANCE	INTERVAL							
	Daily	Every 25 hr.	Every 50 hr.	Every 100 hr.	Every 200 hr.	Every 250 hr.	Every 300 hr.	Every 500 hr.
Check and add engine oil.	●							
Check for loose or lost nuts and screws.	●							
Check for fuel and oil leakage.	●							
Check battery electrolyte level.	●							
◆ Check or clean air inlet screen.	●							
◆ Clean air cleaner paper element.				●				

Oil Level Check

Check oil level daily and before each time of operation. Be sure oil level is maintained. See “PREPARATION” chapter.

Engine Oil Capacity

FR541V	1.5 L [when oil filter is not removed]
FR600V	1.7 L [when oil filter is removed]

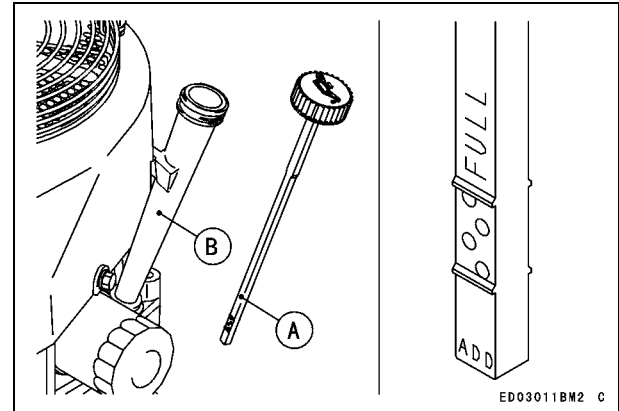

ED03011BM2 C

A. Oil Gauge
B. Oil Filler Tube

26 MAINTENANCE

Oil Change

Change oil every 100 hours or 1 year whichever comes first.

- Run the engine to warm oil.
Be sure the engine (equipment) is level.
Stop the engine.
Remove the oil drain plug and drain the oil into suitable container while engine is warm.

⚠ WARNING

Hot engine oil can cause severe burns. Allow engine temperature to drop from hot to warm level before draining and handling oil.

- Replace the O-ring of the oil drain plug with a new one.
- Apply grease to the O-ring.
- Tighten the oil drain plug.

Tightening Torque

**Oil Drain Plug:
6.9 N·m (0.70 kgf·m, 61 in·lb)**

Remove oil gauge and refill with fresh oil (See “FUEL AND OIL RECOMMENDATIONS” chapter).

Check the oil level (See “PREPARATION” chapter for oil level check).

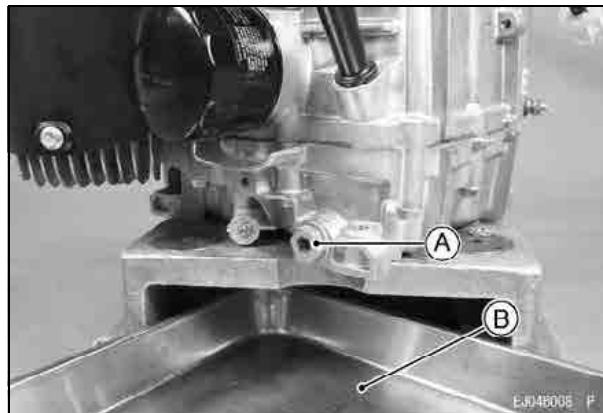

A. Oil Drain Plug
B. Suitable Container

⚠ WARNING

Engine oil is a toxic substance. Dispose of used oil properly. Contact your local authorities for approved disposal methods or possible recycling.

Oil Filter Change

- Change the oil filter every 200 hours of operation.

⚠ WARNING

Hot engine oil can cause severe burns. Allow engine temperature to drop from hot to warm level before attempting to remove oil filter.

- Drain engine oil into a suitable container.

NOTICE

Before removing the oil filter, place suitable pan under filter connection.

- Rotate the oil filter counterclockwise to remove it. Coat a film of clean engine oil on seal of new filter. Install new filter rotating it clockwise until seal contacts mounting surface. Then rotate filter 3/4 turn more by hand.
Supply engine oil as specified.
Run the engine for about 3 minutes, stop engine, and check oil leakage around the filter.
Add oil to compensate for oil level drop due to oil filter capacity (See “PREPARATION” chapter for oil level check).

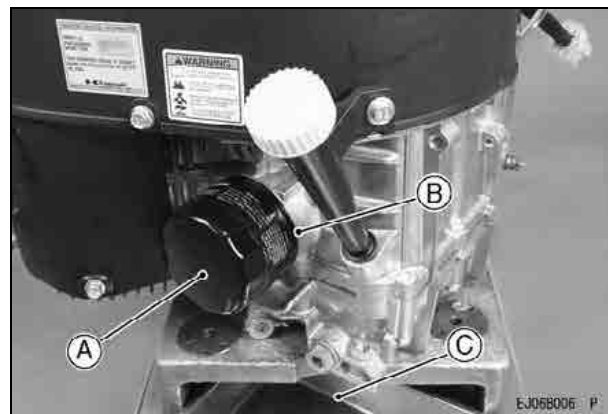

- A. Oil Filter
- B. Mounting Surface
- C. Suitable Container

⚠ WARNING

Engine oil is a toxic substance. Dispose of used oil properly. Contact your local authorities for approved disposal methods or possible recycling.

28 MAINTENANCE

Air Cleaner Service

NOTICE

To prevent excessive engine wear, do not run the engine with the air cleaner removed.

Air Cleaner Element

Lift the air cleaner cover and loose nuts. Remove the air cleaner element.

Clean the paper element every 100 hours.

- Clean the paper element by tapping gently to remove dust. If very dirty, replace the paper element with a new one.

Replace with a new paper element yearly or 200 hours. Whichever comes first.

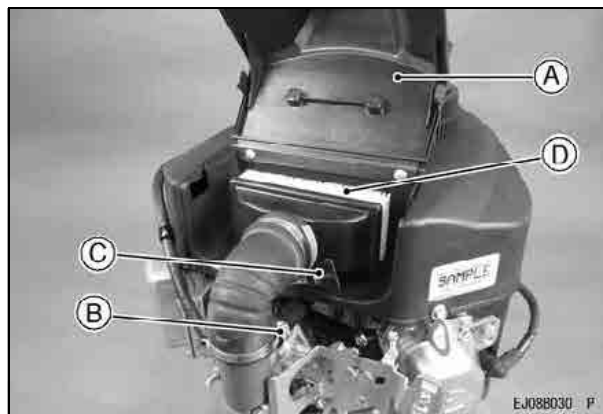

- A. Air Cleaner Cover
- B. C. Nut
- D. Air Cleaner Element

NOTE

- *Operating in dusty condition may require more frequent maintenance than above.*

NOTICE

Do not wash paper element.
Do not oil paper element.
Do not use pressurized air to clean paper element.

Spark Plug Service

⚠ WARNING

Engines can become extremely hot during normal operation. Hot engine components can cause severe burns. Stop the engine and allow it to cool before checking spark plugs.

Clean or replace the spark plugs and reset spark plug gap every 100 hours of operation.

- Disconnect the spark plug caps from the spark plugs and remove the spark plugs.

Clean the electrodes by scraping with a wire brush to remove carbon deposits.

Inspect for cracked porcelain or other wear and damage. Replace the spark plug with a new one if necessary.

Check the spark plug gap and reset if necessary. The gap must be 0.75 mm (0.030 in.). To change the gap, bend only the side-electrode, using a spark plug tool.

Install and tighten the spark plugs to 22 N·m (2.2 kgf·m, 16 ft·lb). Connect the spark plug caps.

RECOMMENDED SPARK PLUG

NGKBPR4ES

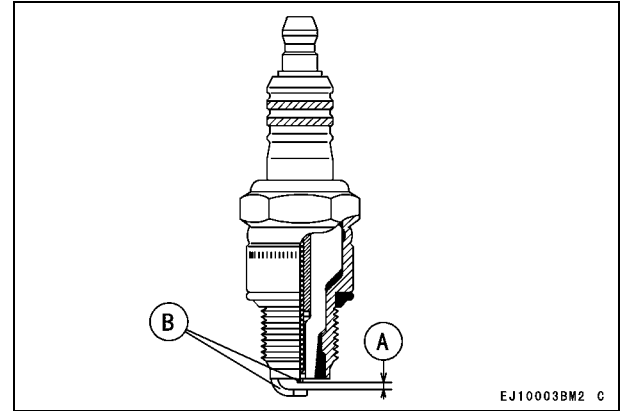

**A. Spark Plug Gap
B. Electrodes**

30 MAINTENANCE

Fuel Filter and Fuel Pump Service

 **WARNING**

Many solvents are highly flammable and may cause serious burns. Improper use of solvents can result in fire or an explosion. Do not use gasoline or low flash-point solvents to clean the fuel filter and/or the fuel pump. Clean only in a well-ventilated area away from sources of sparks or flame, including any appliances with a pilot light.

- The fuel filter can not be disassembled. If the fuel filter gets clogged, replace it with a new one. The fuel pump can not be disassembled. If the fuel pump fails, replace it with a new one.

Cooling System Cleaning

Before each use, check that the air inlet (rotary) screen (inside air inlet guard) is free from grass and debris and clean if necessary. Every 100 hours of operation, check and clean the cooling fins and inside of engine shrouds to remove grass, chaff or dirt clogging the cooling system and causing overheating. When cleaning, remove the air cleaner (inside air cleaner cover), the fuel pump, loosen the bolts and then, remove the fan housing.

NOTICE

Do not run engine before all cooling system parts are reinstalled to keep cooling and carburetion as intended.

[Bolts Size, Tightening Torque]

Bolts	Size	Length	Tightening Torque
C	M6	16 mm	8.8 N·m (0.9 kgf·m, 78 in·lb)
D	M6	22 mm	8.8 N·m (0.9 kgf·m, 78 in·lb)

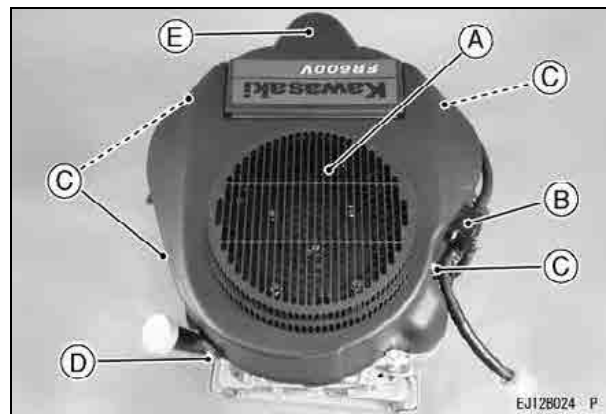

- A. Air Inlet Guard
- B. Fuel Pump
- C. D. Bolt
- E. Air Cleaner Cover

32 MAINTENANCE



F. Fan Housing

STORAGE

Fuel System Draining

Engines to be stored over 30 days should be completely drained of fuel to prevent gum deposits forming on essential carburetor parts, fuel filter and fuel tank.

WARNING

Gasoline is extremely flammable and can be explosive under certain conditions.

Drain fuel before storing the equipment for extended periods.

Drain fuel in a well-ventilated area away from any source of flame or sparks, including any appliances with a pilot lamp. Store fuel in an approved container in safe location.

- Clean every part of the engine.
Be sure that the engine switch or switch key is positioned at "OFF".
Close the fuel valve and remove the sediment bowl.
Put a pan under the fuel valve to receive the drained fuel, and open the fuel valve to drain the fuel from fuel tank completely.

- Install the sediment bowl and open the fuel valve.
- To remove the fuel from the carburetor, run the engine to use up the fuel in the carburetor.
- Remove the spark plugs and pour approx. 1 ~ 2 mL (0.06 ~ 0.1 cu. in.) of engine oil through the spark plug holes and then screw the spark plugs in after turning the engine a few times. Slowly turn the engine until you feel compression and then leave it there. This blocks the air inside the cylinder and prevents rust inside the engine. Wipe the body with oily cloth.
Wrap the engine with plastic sheeting and store it in a dry place.
Change engine oil for next use after period of storage (refer to "Oil Change" section in "MAINTENANCE" chapter).

WARNING

Gasoline is a toxic substance. Dispose of gasoline properly. Contact your local authorities for approved disposal methods.

34 STORAGE

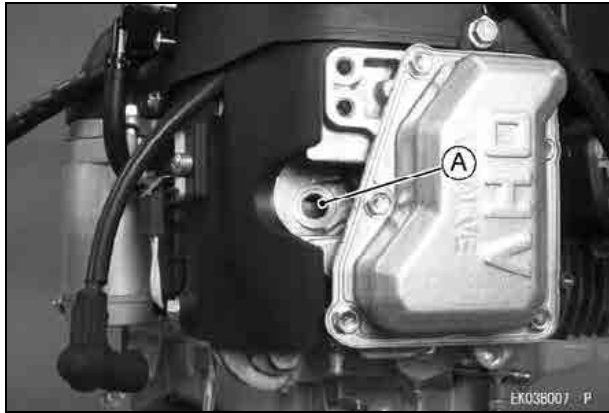

A. Spark Plug Hole

TROUBLESHOOTING GUIDE

If the engine malfunctions, carefully examine the symptoms and the operating conditions, and use the table below as a guide to troubleshooting.

Symptom		Probably Cause	Remedy
Engine won't start or output is low	Insufficient compression	Faulty pistons, cylinders, piston rings, and head gaskets	K
		Faulty valves	
		Loose spark plugs	Tighten properly
		Loose cylinder head bolts	
	No fuel to combustion chamber	No fuel in fuel tank	Fill fuel tank
		Fuel valve not in "ON" position	Open fuel valve lever.
		Blocked fuel filter or tube	Change fuel filter or fuel tube
		Blocked air vent in tank cap	Clean fuel tank cap
		Faulty carburetor	K
	Spark plugs fouled by fuel	Over rich fuel/air mixture	Open choke. Rotate engine with spark plugs removed to discharge excess fuel. Clean spark plugs.
		Clogged air cleaner	Clean
		Faulty carburetor	K
		Incorrect grade/type of fuel	Change fuel
		Water in fuel	

36 TROUBLESHOOTING GUIDE

Symptom		Probably Cause	Remedy
	No spark or weak spark	Faulty spark plugs	Replace spark plugs
		Faulty ignition coil	K
		Engine switch left in "OFF" position	Turn engine switch to "START" position (See M)
Low output	Engine overheats	Clogged air cleaner	Clean
		Air inlet screen or cooling air path clogged with dirt	
		Insufficient engine oil	Replenish or change oil
		Carbon build-up in combustion chamber	K
	Poor ventilation around engine	Select a better location	
	Engine speed won't increase	Faulty governor	K

K: Service to be performed by an authorized Kawasaki dealer.

M: For Control Panel Switch Type, move the throttle lever on the equipment away from its low speed end to turn the engine switch to "START" position.

ENVIRONMENTAL PROTECTION

To protect our environment, properly discard used batteries, engine oil, gasoline, coolant, or other components that you might dispose of in the future.

Consult your authorized Kawasaki engine dealer or local environmental waste agency for their proper disposal procedure.

SPECIFICATIONS

	FR541V, FR600V
Type	Air-cooled, 4-stroke vertical shaft OHV, gasoline engine
Bore × Stroke	73 × 72 mm (2.88 × 2.84 in.)
Displacement	603 mL (36.8 cu.in)
Ignition Type	Fly wheel magneto fixed timing type
Direction of Rotation	Counterclockwise facing the PTO Shaft
Starting System	Electric starter
CO2 engine emission	https://www.kawasaki-engines.eu/en/support/co2-engine-emission-data/

NOTE

- *Specifications are subject to change without notice.*

WIRING DIAGRAM

Wiring Diagram

[Electric Starter Model]

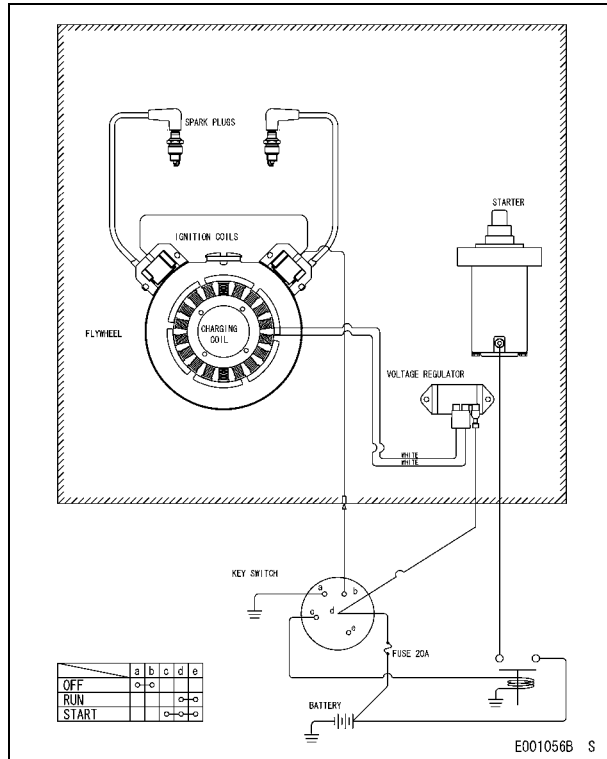

NOTE

○ Portion Surrounded by hatching Shows Kawasaki Procurement Parts.

⚠ WARNING

Prevent sparks and/or electrical system damage by removing the negative (-) cable from the battery before attempting any repair or maintenance.

Battery Capacity Recommended

Battery Capacity

12 V 550 CCA Class



* 9 9 9 7 6 - 2 1 6 3 - 0 6 *

Kawasaki

— ENGINES —

Kawasaki Motors, Ltd.

Printed in Japan